



Original User Instruction Manual

Version C

To be used in conjunction with
SOLOPro+ Original Instruction Manual



IMPORTANT!

Do not use the Minicam equipment for ATEX inspections if:

- You have not been trained in the use of Minicam equipment
- You are not competent in conducting ATEX inspections
- You do not have the correct equipment
- The equipment is suspected as contaminated, malfunctioning, or damaged
- The equipment pressure is low



This instruction manual is applicable to the SOLOPro+ ATEX Zone 1 Inspection System.

A standard system and available options are covered by this document. Depending on your system configuration you may lack some of the features mentioned in this document.

Disclaimer

Hardware and software mentioned in this document are subject to continuous development and improvement. Consequently, there may be minor difference between the information in the document and the performance or design of the product. Specifications, dimensions and other statements in this document are subject to change without prior notice.

Minicam and its suppliers shall not be liable for any damages related to this software or hardware, or for any other damages whatsoever caused by the use of or inability to use any Minicam product. This is applicable even if Minicam has been advised of the damage risk. Under any circumstances, Minicam's entire liability shall be limited to replace such defective software or hardware that was originally purchased from Minicam.

Minicam Limited
Raven Locks, Ravenscraig Road, Bolton, United Kingdom, M38 9PU
Tel: +44 (0)1942 270524 Email: info@minicam.co.uk
www.minicamgroup.com

Company Registered in England & Wales & Company Registration No:
3728693

Contents

Disclaimer	5
Warranty	11
Limited Warranty	11
Extent of the Limited Warranty	11
Conditions of the Limited Warranty	11
Warranty Limitations	11
Introduction	12
Scope of this Operators Manual	12
Use of this Operators Manual	12
If Anything is not Clear	12
Text Conventions	13
Bold Font	13
Lists	13
Procedure Lists	13
Symbols Used in this Manual	14
EC Declaration of Conformity	15
CE Declaration	15
Overview of ATEX Equipment	17
Hazardous Environments	17
ATEX Zones	18
ATEX Compliance and Non-compliance	18
Use of the Equipment	20
Purpose of the Equipment	20
ATEX-1 Equipment Usage	20
Permitted Use of the Equipment	21
General Equipment Usage	22
Operator Responsibilities	24
Fundamental Safety	24
Keeping Safe	24
Positioning of Screens and Control Devices	24
Using the Minicam Equipment	24
Care and Maintenance	25
Repair and Service	25
Spare Parts	25
Servicing Schedule	25

Identifying ATEX System Components	26
ATEX Components Markings	27
CCU210-ExZ1 Control Unit for ATEX-1	27
System Overview	28
Push-camera System	28
ATEX Hazardous and NON-Hazardous Environment Equipment	29
Power Control	30
Steps for Powering ON	30
Step 1: Turning on the System Power	30
Step 2: Decide if to use OVERRIDE to Keep Power ON	30
Step 3: Turning on the Inspection Equipment Power	31
Override Lock	36
CCU210-ExZ1	36
During Inspection Surveying	37
ATEX Mode	37
OVERRIDE Mode	37
Powering OFF the Inspection Equipment Power	38
Preparing for the Inspection	39
Steps to Prepare for the Inspection	39
Selecting the System Components	39
Connecting the System Components Together	42
Powering the System and Inspection Equipment ON	45
Checking the Inspection Equipment Pressures	45
Pressurising Components	46
Checking and adjusting the Internal Pressure	46
Pressure Bar	47
Pressurising the CAM025-ExZ1	48
Pressurising the ExZ1 Camera Spring Assembly	49
Pressurising CAM026L-ExZ1	50
Testing the Pressure Monitoring	51
Steps for the Slow leak test	52
Steps for the Pressure-Drop Test	52
Testing the System Operation Before Use	54
Introducing the Inspection Equipment into the Site	55
Push-camera System	55
During the Inspection	56
Pressure and Compliance Monitoring	56
Pressure Warnings	56

Advisory Warning	56
Cautionary Warning	57
ATEX-1 Pressure Uncompliant	57
Manually Monitoring the Inspection Equipment	58
At the End of the Inspection	59
Removing the Inspection Equipment from the Site	59
Powering the Inspection Equipment OFF	59
Checking the Equipment	59
If you Noticed any Problems	60
Storage and Transportation	60
Appendices	61
Maximum Ratings	62
Troubleshooting	63
WEEE Statement	64

Warranty

Limited Warranty

Congratulations on the purchase of your new SOLOPro+ Hazardous Environment Inspection System. Our products are the result of many years experience and continuous developments. Conscientious manufacturing and checking are essential objectives in our company. Nevertheless failures cannot be excluded totally. If this occurs, you are covered by our generous warranty. Please consider that even the best products can only be durable and work properly with the correct handling and maintenance.

Extent of the Limited Warranty

Minicam warrants that your equipment will be in good working condition and free of defects in material and/or workmanship for a period of one year. If failure occurs, which is provable due to a defect in material and/or workmanship, we will remedy it free of charge during the warranty period. We reserve the right, at our option, to repair the equipment or to replace the whole unit or the faulty parts, or to refund the then current value of the equipment, if we are unable to repair or replace the unit. The warranty is a return to base warranty and we are not liable for any shipping costs.

Conditions of the Limited Warranty

Disassembling the camera, coiler, control unit or any part of the system, without approval of the manufacturer, is forbidden! Non-compliance of this direction will result in the loss of the warranty. The beginning of the warranty period is the date of delivery. This limited warranty does not cover damage due to improper treatment of the system, inadequate maintenance, alteration, repair, normal wear and tear or external causes like lightning, fire or frost. The warranty does not cover wear and tear parts like front camera lenses, O-rings, cable, push rod, rod rollers etc. If you require warranty service please return the system with the original invoice to your dealer or the nearest Minicam Service Centre. Equipment returned must be consigned carriage paid. We will not be liable for carriage costs.

Warranty Limitations

Our responsibility under this warranty is limited to repair, replacement or refund, as set forth above. Minicam is not responsible for direct, special, incidental or consequential damages resulting from any breach of warranty including lost profits, downtime, goodwill, damage to or replacement of equipment and/or property.

Introduction

Scope of this Operators Manual

Minicam equipment falls into the following classes:

NON-ATEX is not approved for Hazardous Environments, and is usable only where there is deemed no possibility of Hazardous Environment.

ATEX-2 is approved for use in ATEX Zone 2 Hazardous Environments. The equipment is self-monitoring, and provides warnings to the user, but does not automatically remove inspection equipment power in the case of a problem.

ATEX-1 is approved for use in ATEX Zone 1 (and Zone 2) Hazardous Environments. The equipment is self-monitoring, and provides warnings to the user, and will automatically remove inspection equipment power in the case of a problem.

This Operators Manual describes the **ATEX-1** system requirements and operations.

For descriptions of all the additional system functionality and features outside of ATEX, please refer to the *SOLOPro+ Original Instruction Manual*.

Use of this Operators Manual

This Operators Manual is an addition to the *SOLOPro+ Original Instruction Manual*, with which it must be read in conjunction.

This manual contains important procedures and instructions which must be followed, particularly when using the ATEX-1 equipment. You must comply with the contents of this manual plus the *SOLOPro+ Original Instruction Manual*.

All Operators are required to have in-depth knowledge of these manuals before using Minicam equipment. The manuals contain important information about how the system works and the information the system provides. Understanding and following these will minimise operational risks and help prolong the life of the system.

If Anything is not Clear

If you are unsure at all of any area of usage of Minicam equipment, please contact your designated Minicam Service Centre, see: www.minicam.co.uk/partner-dealers

Text Conventions

In this user manual the following text conventions are used:

Bold Font

Bold font is used for important words.

For example: This **must not** be done in reverse order.

Lists

Lists are marked as follows:

- Item 1
- Item 2

Procedure Lists

Procedures that must be performed in a specific order appear in numbered lists like this:

- 1** Perform this step first.
- 2** Perform this step second.

Symbols Used in this Manual

In this user manual the following symbols are used:



CAUTION

Caution means that you must take particular note or actions to minimise risks to safety.



POTENTIAL FOR EXPLOSION

This indicates potential explosion hazards and other dangers which can seriously compromise safety and may result in serious injury or death.



DAMAGE

Indicates instances where the inspection equipment or other property could be damaged.



NOTE

Notes give important information or guidance.



CARE

Highlights the recommended care regime required to maintain the long life of the equipment, but also importantly for ensuring compliance with the ATEX requirements.

EC Declaration of Conformity

CE Declaration

We Minicam. Raven Locks, Ravenscraig Road, Bolton, United Kingdom, M38 9PU hereby declare that the SOLOPro+ ATEX System Components to which this declaration refers are in compliance with the following standards or standardizing documents where applicable to the component:

EN61000-6-4: 2007 + A1: 2011	Electromagnetic compatibility (EMC) Part 6-4: Generic standards - Emissions for industrial environment.
EN61000-6-2: 2005	Electromagnetic compatibility (EMC) Part 6-2: Generic standards - Immunity for industrial environment.
IEC 60079-0:2017	Explosive atmospheres - Part 0: Equipment - General requirements
IEC 60079-2:2014-07	Explosive atmospheres - Part 2: Equipment protection by pressurized enclosure "p"

The following are the stipulated operating and environmental conditions for said compliance:

Residential, business, commercial, small-company and light industrial environments.

This declaration is based on test report(s) of the relevant EMC testing laboratory.

Overview of ATEX Equipment

ATEX equipment is approved for use in Hazardous Environments, where there is some potential for presence of explosive atmospheres.

To protect against Hazardous Environments, Minicam inspection equipment is pressurised internally, which prevents any Hazardous Environment from entering the equipment, where it might be subject to sources of ignition.

Hazardous Environments

Environments where the inspection equipment is being used can be either *Hazardous* or *NON-Hazardous*.

- A **Hazardous** Environment is where there is a potential for explosive atmospheres.
- A **NON-Hazardous** Environment is where there is NO potential for explosive atmospheres.



You or a qualified person must decide whether the Environment in which the inspection equipment is being used is Hazardous or NON-Hazardous. The system cannot detect if an Environment is Hazardous or not.



You must only pressurise, or perform maintenance, or change of equipment in a NON-Hazardous Environment. You must **NEVER** open, disconnect, or reconnect inspection equipment in a Hazardous Environment.

ATEX Zones

Minicam equipment is classified according to its approvals for use in different Environments:

- **ATEX-1** – the highest level of ATEX that Minicam equipment supports. This is specialised equipment containing several high integrity design and pressure monitoring features, and a means of automatically cutting off the power supply to the inspection equipment if any low pressure condition is detected.
- **ATEX-2** – this equipment contains good pressure monitoring features, designed to meet the ATEX-2 regulations for use in explosive environments, but will **NOT** automatically remove the inspection equipment power supply if a low pressure condition is detected.
- **NON-ATEX** – this equipment still contains pressure sensing features, but is **NOT** approved for use in any explosive environments.



You or a qualified person must determine the required level of ATEX equipment, and you must use only equipment which meets those levels.

ATEX Compliance and Non-compliance

ATEX equipment can be *Compliant* or *Uncompliant*.

When powered ON, the system continuously monitors the pressures inside the ATEX equipment. If the pressures are high enough, the equipment is *Compliant*. If they fall too low, the equipment is *Uncompliant*.

NON-ATEX equipment, even when pressurised, can never be classed as being Compliant, as it does not meet the other design regulations required for full ATEX compliance.

If *any* attached ATEX equipment becomes Uncompliant, then the *whole system* is deemed Uncompliant.

So for example where the camera and coiler are used together, if only the camera becomes Uncompliant but the coiler is still Compliant, the *whole system is deemed Uncompliant*.



You must only use ATEX equipment that is *all Compliant* when it is in use in Hazardous Environments.

Use of the Equipment

Purpose of the Equipment

The Minicam equipment is for the purpose of pipeline inspections, and any other use is not permitted. If the equipment is used for any other purpose, Minicam disclaim responsibility or liability for any warranty or claim of any kind.

ATEX-1 Equipment Usage

Minicam ATEX-1 equipment may be used according to these standards:

IEC 60079-0 2018

Explosive atmospheres - Part 0: Equipment - General requirements

IEC 60079-2 2015

Explosive atmospheres - Part 2: Equipment protection by pressurized enclosure "p"

IEC 60079-7 2015

Explosive atmospheres - Part 7: Equipment protection by increased safety "e"

Permitted Use of the Equipment

Use of the SOLOPro+ ExZ1 pipeline inspection system in Hazardous Environments is only permitted providing, at minimum, ALL of the following are adhered to (this is not a complete list):

- Operators have been trained in use of the equipment.
- Operators have been trained in ATEX and the requirements of the ATEX standards.
- The correct and appropriate equipment is being used.
- The Operators manual needs to be kept with the equipment and referred to whenever needed.
- The use of the OVERRIDE Key must be understood and all implications accepted by the Operator.
- **ALWAYS** take heed of any system indicated warnings or other information.

- The procedures and steps in this manual **MUST** be followed.

General Equipment Usage

DO:

- Act upon any system warnings at all times.
- Stay alert and attentive of the system at all times.
- Power ON only when certain the inspection equipment is not in a Hazardous Environment.
- Regularly test the pressure monitoring system.
- Ensure pressures are adequate before placing inspection equipment in a Hazardous Environment.
- Purge and re-pressurise only in a NON-Hazardous Environment.
- Use the correct and appropriate equipment for the inspection's requirements.
- Switch off if the system shows any signs of any problem.
- Switch off and not use the equipment if it generates excessive heat.
- Stop using equipment in Hazardous Environments if you suspect it might have become damaged.
- Keep the Operators Manuals always at hand.
- Disconnect or connect components only when powered down.
- Use only the approved accessories.
- Check condition of all connectors and ensure they are firmly attached before use.
- Visually inspect all equipment before use.

- Use the protective caps and covers when equipment is not in use.
- Wear applicable personal protective gear (for example gloves, hard hat, ear protection etc).

DO NOT:

- Do not use the equipment if in any doubt.
- Never pressurise, open, disconnect, or connect components in Hazardous Environments.
- Do not attach any unapproved components, materials or devices to the equipment.
- Never begin using damaged or malfunctioning equipment, however slight.
- Don't use Minicam equipment near sensitive other electrical equipment.

REMEMBER:

- ATEX equipment is only serviceable by a Minicam certified Service Centre.

Operator Responsibilities

Fundamental Safety

The Operator is responsible for using the Minicam equipment safely under all conditions. You as the Operator must have competent knowledge of the ATEX requirements and of the Minicam equipment. The Minicam ATEX-1 equipment contains an automatic power removal in the instance of low equipment pressure, but contains no other automatic safety features. There is reliance on you as the Operator to stay alert and observant.

Keeping Safe

You as the Operator, and anyone associated with the inspection, must:

- Comply with all instructions in this manual and associated manuals.
- Keep this manual and associated manuals accessible at all times.
- Be trained in use of the Minicam equipment, and keep that training up-to-date.
- Comply with any safety regulations that pertain to your work.
- Keep records of usage, any observed problems, servicing and repairs, and keep your co-workers informed.
- Keep your knowledge updated with best working practices and comply with them.
- Comply with any client or company process or procedures in force.

Positioning of Screens and Control Devices

Important information is shown on the system display screens, and the system requires interaction by the Operator. It is vital to ensure that the system keyboard and joysticks are readily accessible, and that the display screens are visible to the Operator at all times.

Using the Minicam Equipment

The Operator is responsible for the use of the Minicam equipment under all conditions. You as the Operator or a qualified person must:

- Determine whether the inspection requires some level of ATEX protection.
- Ensure that the equipment is undamaged and in working order before commencing the inspection.
- Stop the inspection if you have any reason to believe there is a

system fault or damage.

- Assess the safety of the inspection site and any prevailing weather conditions.

Service and Repair of ATEX Equipment

Only Minicam certified appointed Service Centres are permitted to perform any servicing, internal examination or any repairs on ATEX equipment.

Care and Maintenance

For general care and maintenance, refer to the *SOLOPro+ Original Instruction Manual*. On ATEX equipment the care and maintenance procedures are essential not only for promoting long life of the equipment, but also importantly for ensuring compliance with the ATEX requirements.

Repair and Service

Only Minicam certified appointed Service Centres are permitted to perform any servicing, internal examination or any repairs on ATEX equipment. You must not have the equipment serviced, internally examined or repaired by an unauthorised person. Not only will this invalidate any warranty, but can also immediately invalidate any ATEX compliance certification.

Spare Parts

Contact your Minicam Service Centre if you require spare parts (some parts may have to be fitted by the Service Centre).



If you suspect the equipment is contaminated, malfunctioning or damaged, do not use the equipment and contact your Service Centre.

Servicing Schedule

The Minicam ATEX equipment must be regularly serviced to check and maintain its performance, and ensure that it complies with ATEX standards. Minicam recommends that even if you do not suspect that your ATEX equipment has problems, you need to have it serviced and inspected at least once every year. If the ATEX equipment is used on a double-shift pattern, Minicam recommends servicing every 6 months. This will ensure that the ATEX equipment operates at maximum efficiency.

Identifying ATEX System Components

Equipment for use in ATEX Zone 1 Hazardous Environments has at least one of these markings:

An ExZ1 Serial Number



An ATEX-1 Specific Marking



Only ATEX markings containing "**2G**" are for use in ATEX-1 Environments. No other marking is permitted.

ATEX Components Markings

All SOLOPro+ ATEX components are marked with the EX symbol . You must not use any other system components for ATEX.

CCU210-ExZ1 Control Unit for ATEX-1

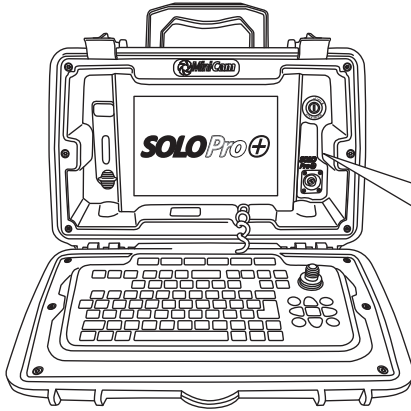

ATEX Identification

CCU210-ExZ1

EX Logo & OVERRIDE

Key



System Overview

Push-camera System

The SOLOPro+ ATEX Zone 1 Inspection System consists of the following main components:

- Coiler (A)
- Control Unit (B)
- Camera (C)

A typical configuration is shown in this illustration:

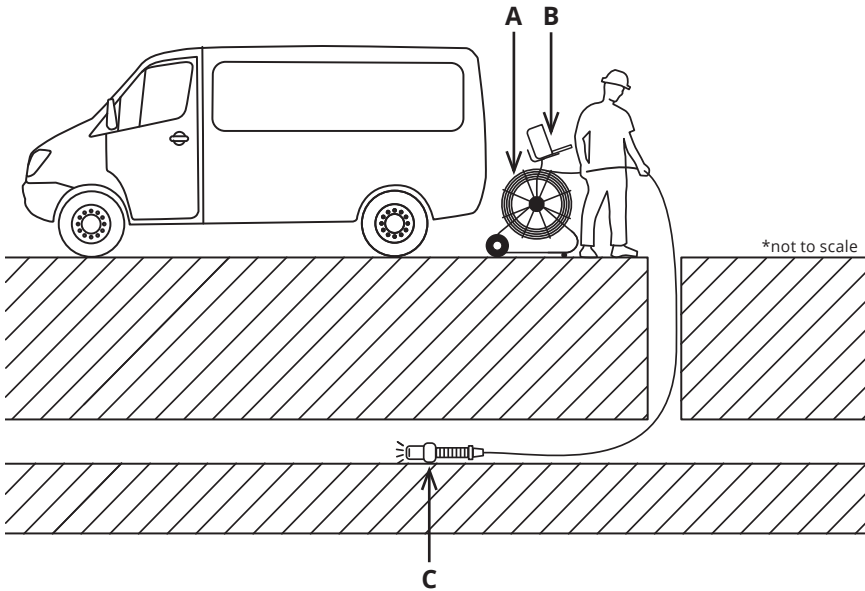

The actual extent of the Hazardous Environment for each inspection will be defined by the nature of the inspection itself. YOU or a qualified person must determine the extent of the Hazardous Environment for each particular inspection.

ATEX Hazardous and NON-Hazardous Environment Equipment

Some parts of the system are permitted in the Hazardous Environment. These are marked as such (see Identifying ATEX System Components page 26).

Any equipment which is **NOT** marked as permitted must **NEVER** enter the Hazardous Environment. Examples of such equipment are the control panel, screens, coiler, rod and cable reel - this is **NOT** a complete list – always assume that if equipment is **NOT** marked as **ATEX** then it **MUST NOT** enter the Hazardous Environment.

Power Control

Steps for Powering ON

First follow the steps in section *Preparing for the Inspection* page 39, then:

Step 1: Turn on the System Power

Step 2: Decide if to use the OVERRIDE Key

Step 3: Turn on the Inspection Equipment Power

Step 1: Turning on the System Power

Press the PowerON key 

When you first turn on the system using the PowerON key, the CCU will start up but the power to the inspection equipment will remain OFF. You must tell the CCU when to apply the power to the inspection equipment. Once the system has started, you must read and accept any messages.



If the inspection requires ATEX, you must ensure that the inspection equipment is in a NON-Hazardous Environment before you apply power to the inspection equipment.

Step 2: Decide if to use OVERRIDE to Keep Power ON

For instructions on using of the OVERRIDE Lock (see page 36).

The ATEX-1 monitoring system automatically removes inspection equipment power if any equipment pressures are low. But this would make it impossible for the ATEX-1 inspection equipment to report its pressures when you need to re-pressurise it to the correct values. For this reason the OVERRIDE Key can be used to force ATEX-1 inspection equipment power to remain ON even when pressures are low.



If you have no reason to use OVERRIDE, ensure the key is not in the OVERRIDE position.



Remember to turn the OVERRIDE Key back when you no longer need to use OVERRIDE.

Step 3: Turning on the Inspection Equipment Power



If the inspection requires ATEX, you must ensure that the inspection equipment is in a NON-Hazardous Environment before you apply power to the inspection equipment.

Request Inspection Equipment Power ON

Press the Power On/OFF key 

Authorise Inspection Equipment Power

Now you need to Authorise the power to the inspection equipment.

For ATEX-1, if the key is in the OVERRIDE position (see page 36) you are shown an OVERRIDE warning message like this:

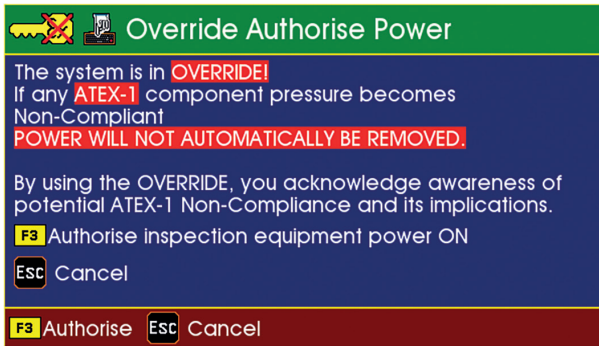

In all other cases, you are shown a warning message like this:

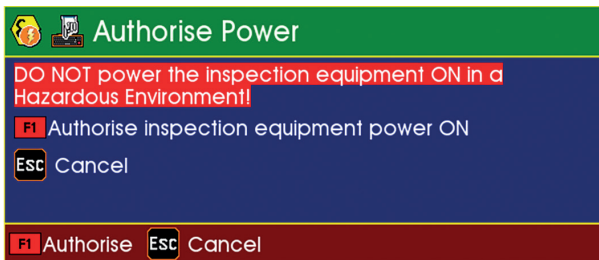

You might need to enter a pass-code to confirm that you authorise the inspection equipment power ON. Enter the pass-code if you are asked to (the

pass-code is not required on all systems).

Read and understand any messages shown on-screen, then to Authorise the inspection equipment power:

Press the Yellow  key if in OVERRIDE.

or

Press the Red  key in all other cases.

Turn On Inspection Equipment Power

Now you are asked to press Power ON/OFF key again – which will actually turns on the power to the inspection equipment.



Ensure that the inspection equipment is in a Non-Hazardous Environment before turning on the power.



Read and understand any messages shown on-screen, then press the Power ON/OFF key to power the inspection equipment ON.

Upon pressing the Power ON/OFF key, the CCU applies power to the inspection equipment, then automatically detects its capabilities. The system performs some checks, and will tell you if there are any problems. The system then shows you the ATEX Zone mode that it has selected based on the detected capabilities of the attached equipment. From then on, the power to the equipment remains ON until one of the conditions occurs to remove the power.

The inspection capabilities are shown thus:

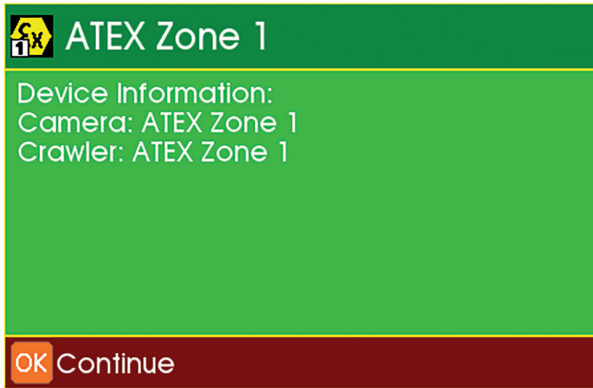

If performing an ATEX-1 inspection, ensure the system is showing that ATEX-1 Zone mode is detected.

The equipment is then ready for use in the Hazardous Environment.



You should check the inspection equipment pressures are adequate for the whole duration of the inspection before starting the inspection. If the pressures run low during the inspection you may have to abandon the inspection.

Maintaining the Inspection Equipment Power ON

Power to the inspection equipment will remain ON until a condition happens that causes power to be removed.

Conditions under which the system will keep power ON the inspection equipment:

- Whenever the key is in OVERRIDE position.
- When operating in ATEX-1, and all ATEX-1 inspection equipment is Compliant.

Conditions under which power will be REMOVED from the inspection equipment:

- You press the PowerON key . The icon is a black rectangular button with a white power symbol (a circle with a vertical line) on the left and the text 'Power ON/OFF' on the right.

Conditions under which power will be AUTOMATICALLY REMOVED from the inspection equipment:

- ATEX-1 inspection equipment becomes Uncompliant and the key is **NOT** in OVERRIDE.
- The main power supply to the system is lost.
- A cable becomes detached.
- The system detects a malfunction within itself.

Override Lock

The SOLOPro+ CCU210-ExZ1 features an OVERRIDE Lock as shown below. See page 37 for instructions on how to use the OVERRIDE Lock.

CCU210-ExZ1

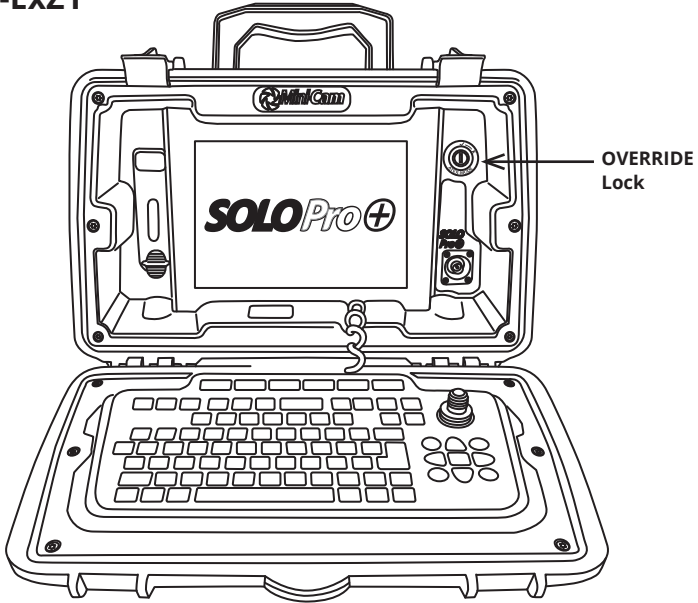

The OVERRIDE Key (see previous page) can be in either of two positions:

- ✓ **ATEX Mode**
- ✗ **OVERRIDE Mode.**

During Inspection Surveying

ATEX Mode

with the key in this position, the ATEX-1 uncompliant power cut-off is enabled. If the system detects ATEX uncompliant, the power supply to the inspection equipment will be cut off. You **MUST** always operate the system with the key in this position unless you have a good reason to use the OVERRIDE Mode position. You can remove the key when it is in the ATEX Mode position.

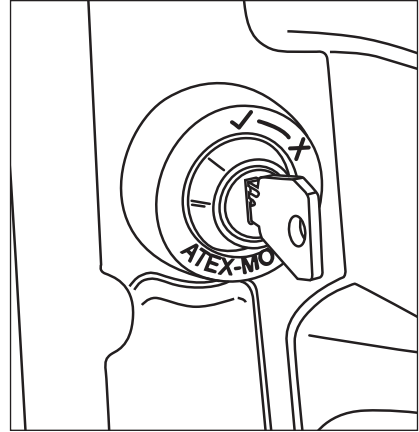

OVERRIDE Mode

With the key in this position, the ATEX-1 uncompliant power cut-off is disabled. If the system detects ATEX uncompliant, the power supply to the inspection equipment will **NOT** be cut off. You cannot remove the key when it is in the ATEX Mode position.

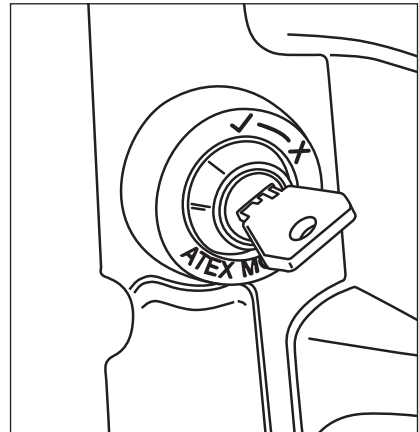

You must **ONLY** use OVERRIDE Mode if you are certain that the equipment is **NOT** in a Hazardous Environment.

Powering OFF the Inspection Equipment Power

Manually Powering OFF the Inspection Equipment Power

You can choose to power OFF the inspection equipment at any time by pressing the Power  key



When conducting an ATEX inspection, if the inspection equipment has been powered OFF, you or a qualified person **MUST** ensure that the inspection equipment is in a NON-Hazardous Environment before you power it back on again.

ATEX-1 Automatically Powering OFF the Inspection Equipment Power

When in ATEX-1 Zone mode, the system itself can determine to power OFF the inspection equipment at any time automatically.

If the power is OFF because the system detected non-compliance, the only way to re-power the inspection equipment back ON is to use OVERRIDE.

If you wish to use OVERRIDE, turn the key to OVERRIDE, then follow the instructions for *Power Control* on page 30.



YOU or a qualified person must assess that the inspection equipment is in a NON-Hazardous Environment before you use OVERRIDE to power it back on again.

ATEX-1 Resetting and Restarting ATEX-1 Monitoring

Once the system has automatically removed the inspection equipment power because of ATEX-1 Uncompliant, you can reset and restart the ATEX-1 monitoring system by turning the OVERRIDE key to the OVERRIDE position, then turning it back to the ATEX position.

Preparing for the Inspection

Steps to Prepare for the Inspection

If performing an ATEX inspection, ensure you are trained and are competent in ATEX, and in the use of this system.

Follow these steps to prepare for the inspection:

- Step 1** Select the appropriate system components
- Step 2** Connect the system components together
- Step 3** Power the system and inspection equipment ON (using OVERRIDE if necessary)
- Step 4** Check the component pressures
- Step 5** Test the Pressure Monitoring
- Step 6** Test the system operation
- Step 7** Introduce the inspection equipment into the site

Selecting the System Components

You need to select and use the correct inspection equipment components for the Environment requirements of the inspection. Generally this will be one of:

- **ATEX-1** is required
- **ATEX-2** is required
- There is **no** requirement for ATEX

ATEX Zone Modes

The system operates in one of three ATEX Zone modes, according to what inspection equipment is attached:

- **ATEX-1** – ALL attached equipment is ATEX-1 approved.
- **ATEX-2** – ALL attached equipment is ATEX-2 approved.
- **NON-ATEX** – ANY attached equipment is neither ATEX-1 or ATEX-2.

Auto-Detecting the Zone Mode for the Attached Inspection Equipment

The system auto-detects the ATEX capabilities of the attached equipment when you power the equipment on. The system then shows you the ATEX Zone mode that it has selected based on the attached equipment.



You must ensure that you select the correct ATEX Zone equipment for the inspection, and ensure that the system is indicating the correct ATEX Zone mode before you commence the inspection.

Equipment for use in Hazardous and NON-Hazardous Environments

See *Identifying ATEX System Components* page 26.

Equipment that is suitable for use in Hazardous Environments will have a label or marking to say so. Generally this is limited to the inspection equipment such as the camera, crawler, sonde, rod, cable, and other devices that are approved by Minicam to use with the inspection equipment.



When in Hazardous Environments you must only use approved Minicam equipment. **DO NOT** attach or use any other devices.

Equipment that must **NEVER** be used in Hazardous Environments will have

no label or marking. Generally this would include for example a rod coiler, cable reel, CCU, and main power supply.

Choosing the Appropriate Inspection Equipment System Components

See *Identifying ATEX System Components* page 26.



You must only use the appropriate minimum level of ATEX equipment for the particular Environment.

- If the Environment requires ATEX-1, you must use ATEX-1 equipment.
- If the Environment requires ATEX-2, you must use either ATEX-1 or ATEX-2 equipment.
- If the Environment does **NOT** require ATEX, you can use ATEX-1, or ATEX-2, or NON-ATEX equipment.



Never use NON-ATEX equipment for ATEX inspections, or when there is a chance of encountering a Hazardous Environment.

Connecting the System Components Together

Check the Condition of the Components

Before connecting any components together, always thoroughly inspect the condition of all components, especially cables, connectors, pins and camera glass.



Do not use any equipment showing signs of contamination, malfunction or damage, however slight.

Connect the Components Together

Only connect and disconnect components with the system power OFF.



For ATEX inspections, only connect and disconnect components in a NON-Hazardous Environment.

Connect the components, paying attention to connector orientation and ensuring that all connections are robust.

Push-camera Connection

Minicam ATEX compliant cameras are exclusively compatible with Minicam ATEX compliant equipment. This section explains how to fit a Minicam ATEX compliant camera to the Push-camera coupler.

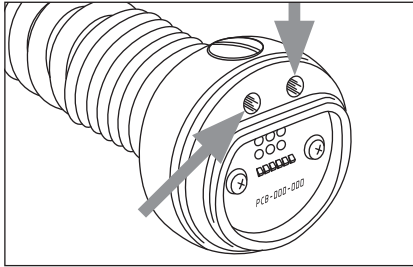

1 Minicam ATEX compliant cameras feature two location holes which ensure that the camera can only be used with Minicam ATEX compliant equipment.

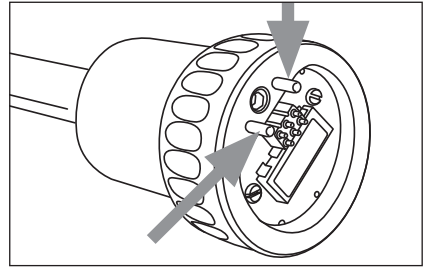

2 The coupler has two locator pins, designed to ensure that only a Minicam ATEX compliant camera can be connected to Minicam ATEX compliant equipment

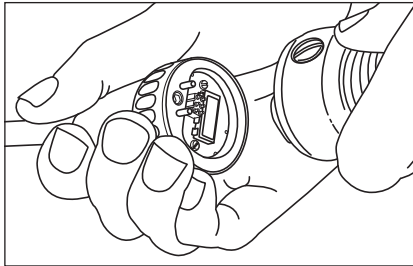

3 To fit the camera, offer the camera connector to the coupler ensuring that the locator pins on the camera are correctly aligned to the locator holes on the coupler.

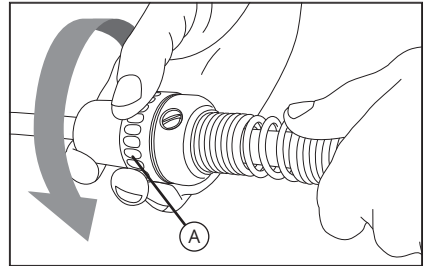

4 Screw the Coupler Locking Ring (A) onto the camera connector in the direction shown ensuring a tight seal is achieved.

Rear Connection Skid

For ATEX compliance it is compulsory that the Rear Connector Skid is fitted.

The Rear Connector Skid prevents the connector from becoming loose and losing pressure.

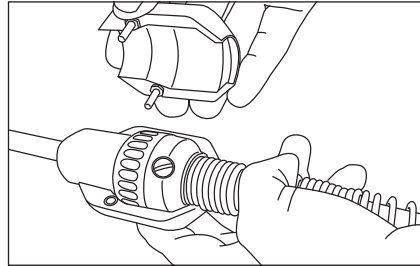

1 Align the lower half of the Rear Connector Skid beneath the Sonde.

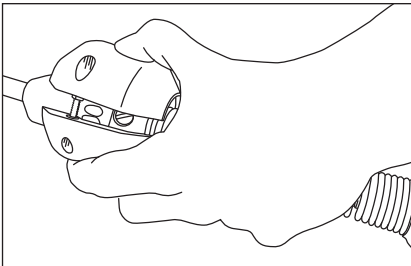

2 Align the top half of the Rear Connector Skid above the Sonde.

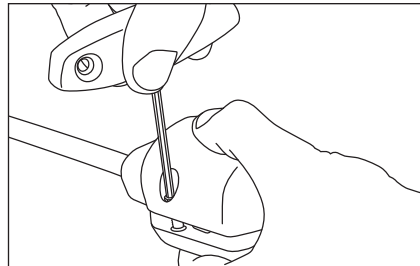

3 Use a 3mm T-Bar to screw and secure the two halves of the Rear Connector Skid together.

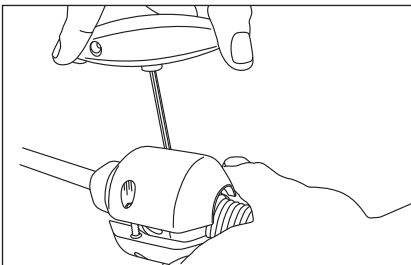

4 Repeat step 3 on opposite screw.

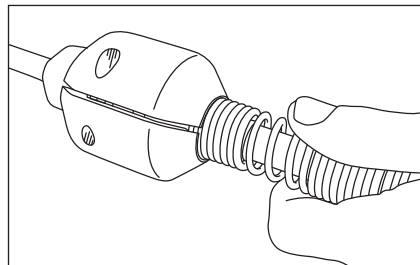

5 Ensure both screws are fully tightened.

Powering the System and Inspection Equipment ON

See section *Power Control* page 30.

Checking the Inspection Equipment Pressures



Before commencing an inspection you should check that the pressures of the inspection equipment are adequate for the duration of the entire Inspection. If pressure runs low during the inspection you may have to abandon the inspection.

Pressurising Components

Prior to performing an inspection, YOU **must** pressurise all components with pressure-encapsulated housings and to check the pressure, so that you ensure the tightness of all components. For the pressure test it is important that all system components are assembled, the coiler is connected to the camera and the control panel is in operation.



Only nitrogen is permitted as a pressurisation gas.

Checking and adjusting the Internal Pressure

If pressure has been removed completely from a system component, it is necessary to re-pressurise that system component with nitrogen (see page 48, page 49, and page 50) and to completely remove the pressure again afterwards. This procedure of pressurising with nitrogen must be repeated five times in total. This is to ensure that no explosive mixture in a flammable concentration will be present inside the equipment.



DO NOT over pressurise the components, this could lead to damage and non-compliance.



Only pressurise components in a NON-Hazardous Environment.



You may need to use the **VERRIDE** Key to maintain power ON while pressurising, see *Power Control* page 30.

Illustrated instructions on how to pressurise SOLOPro+ ExZ1 components can be found as follows:

- CAM025-ExZ1 Self Levelling Axial Camera page 48
- ExZ1 Camera Spring Assembly page 49
- CAM026L-ExZ1 Pan, Rotate & Laser Camera page 50

Pressure Bar

The pressure of equipment is shown as a coloured bar. Low pressure is to the left, higher pressure is to the right. If the equipment has two pressure sensors, two bars will be shown.

All equipment should be pressurised into the green area.

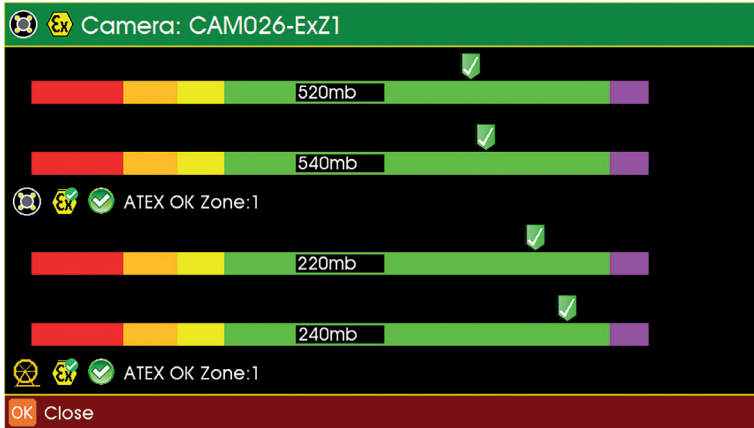

RED AREA	Pressure too low / uncompliant
ORANGE AREA	Pressure low caution
YELLOW AREA	Pressure low advisory
GREEN AREA	Pressure OK
PURPLE AREA	Pressure too high, though still compliant



If pressures are in the ORANGE or YELLOW area, it is advisable that the equipment is repressurised before use, or there is risk that the pressures will fall too low during the inspection.

For ATEX it is essential that the equipment pressure is not in the RED area - indicating pressure is too low and non-compliant.

Pressurising the CAM025-ExZ1

- 1 Connect the SOLOPro+ ExZ1 inspection system and apply power.
- 2 Unscrew the pressure valve protection cap (A) and screw on the pressure valve (B).
- 3 Fill the module with Nitrogen until the pressure bar is at least in the middle of the GREEN area.
- 4 Wait 60 seconds.
- 5 To release the pressure, use the valve key.
- 6 Repeat steps 3,4 and 5 a further four times.

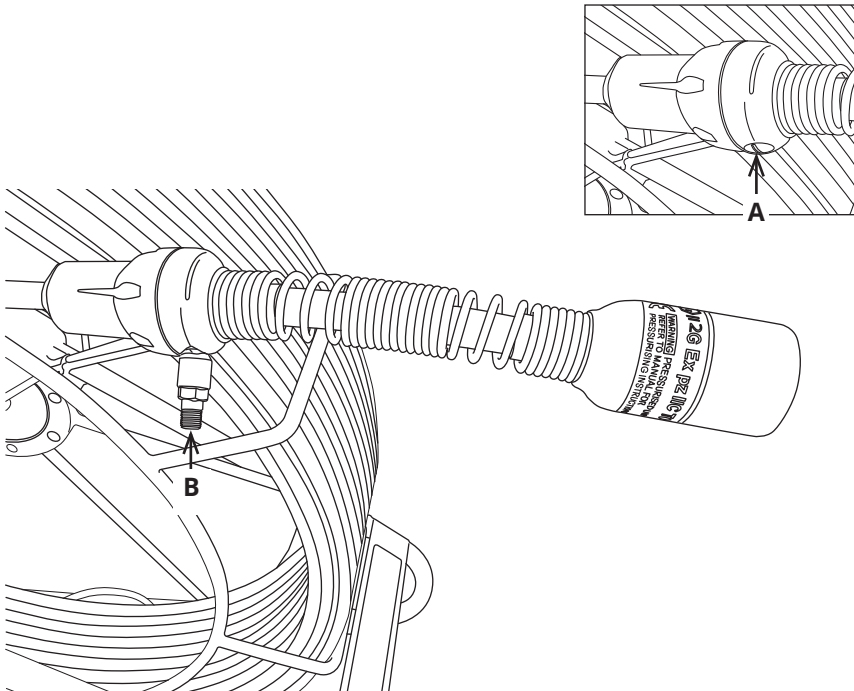

Pressurising the ExZ1 Camera Spring Assembly

- 1 Connect the SOLOPro+ ExZ1 inspection system and apply power.
- 2 Unscrew the pressure valve protection cap (**A**) and screw on the pressure valve (**B**).
- 3 Fill the module with Nitrogen until the pressure bar is at least in the middle of the GREEN area.
- 4 Wait 60 seconds.
- 5 To release the pressure, use the valve key.
- 6 Repeat steps 3,4 and 5 a further four times.

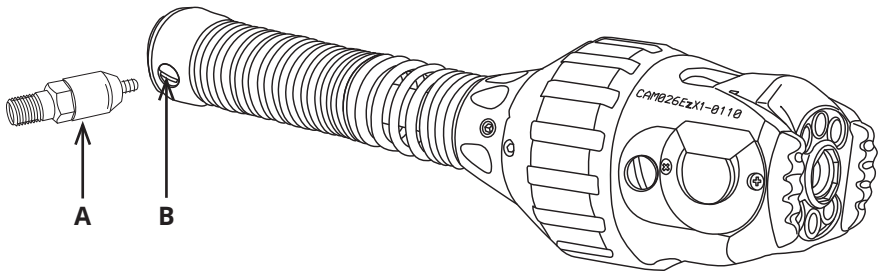

Pressurising CAM026L-ExZ1

- 1 Connect the SOLOPro+ ExZ1 inspection system and apply power.
- 2 Unscrew the pressure valve protection cap (**B**) and screw on the pressure Valve (**A**).
- 3 Fill the module with Nitrogen until the pressure bar is at least in the middle of the GREEN area.
- 4 To release the pressure, open the purge screw (**C**).
- 5 Repeat Steps 3 and 4 a further 4 times .
- 6 Remove the pressure valve (**A**).
- 7 Refit the protection cap (**B**).

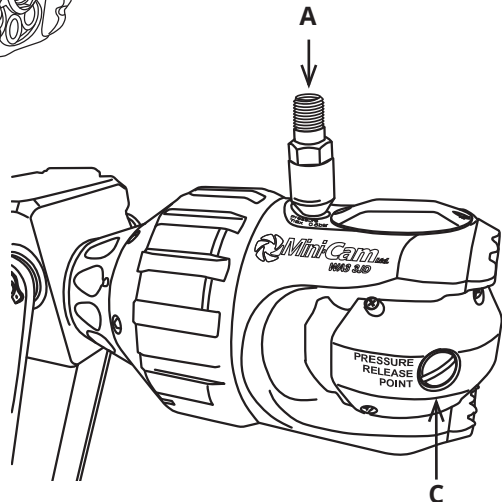
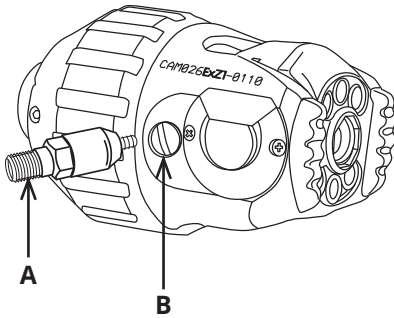

Testing the Pressure Monitoring

It is good practice to periodically test the ATEX Compliance Detection System. The tests must only be performed in a NON-Hazardous Environment.



You need to test the Camera and Coiler components separately. Perform the tests below on each component of the inspection equipment in turn.

Steps to Prepare for the Tests

- Ensure the inspection equipment is in a NON-Hazardous Environment.
- Connect the inspection equipment to the system.
- Turn the OVERRIDE key to OVERRIDE.
- PowerON the system.
- Turn on the inspection equipment power (see *Power Control* page 30).
- If the pressure of any component of the inspection equipment is already low, you should see a warning. Press OK to clear the warning.
- Press Help, then the coloured key for Camera.
- The Compliance status of the connected inspection equipment is shown, along with the current pressures.
- Follow the procedures for pressurising the inspection equipment (see *Pressurising Components* page 46).

The Help screen should now say that all attached equipment is Compliant and of adequate pressure. The system is now ready for testing.

Steps for the Slow leak test

Prepare for this test with the inspection equipment pressures Compliant and adequate, then:

- Take a note of the inspection equipment pressures, then leave the equipment powered on and unused for 30 minutes.
- After 30 minutes, the pressures of the equipment should not have appreciably decreased (it is OK if the pressures have increased; this is due to the internals of the inspection equipment warming up).
- If pressures HAVE appreciably decreased, or a pressure WARNING is showing, the inspection equipment is NOT suitable for ATEX.



If this test fails, do not use the equipment for ATEX, and consult your Minicam Service team.

Steps for the Pressure-Drop Test

Prepare for this test with the inspection equipment pressures Compliant and adequate, then:

- Ensure the OVERRIDE key is in the ATEX position.
- Turn up the camera illumination (see section "Camera Function Keys" in the *SOLOPro+ Original Instruction Manual*) such that the camera lights are visibly ON.
- Manually cause a release of the inspection equipment pressure, by opening the purge valve slowly on the device.

The system should show a series of warnings as the pressure drops:

- Pressure low advisory
- Pressure low caution
- Pressure non-compliant

On ATEX-1 systems, when non-compliant pressure is reached, the system should also remove power to the inspection equipment.



You can tell that the power supply has been removed, as the camera illumination lights will go OFF.



If the Uncompliant warning is **NOT** shown, the system is **NOT** suitable for ATEX.



For ATEX-1, if the inspection equipment power is **NOT** removed, the system is **NOT** suitable for use.



For ATEX, if any test fails, do not use the inspection equipment, and consult your Minicam Service team.



After performing these tests, the OVERRIDE key must be returned to the ATEX position before using the inspection equipment for ATEX-1 inspections.



After manually releasing the inspection equipment pressure, it **MUST** be re-pressurised again before use.

Testing the System Operation Before Use

Test the system before use to make sure the system performs correctly.



Risk of serious injuries by falling coiler!

During the testing of the system make sure that the coiler is not positioned too close to the open manhole, and is positioned on a flat surface to avoid any risk of the coiler over-balancing. Any person in close proximity may suffer serious injuries.



Risk of disorientation and temporary blindness!

The illumination on the SOLOPro+ inspection system uses high power LED lighting with narrow angle secondary optics. During the testing and use of the system never look directly at the camera. When checking the illumination use a low power setting and view from an angle greater than 50° from the centre of the module.

Check the following system functions:

1 Extended Rod:

- Ensure a clear-run down the manhole and into the pipeline.

2 Friction Brake:

- Ensure the friction brake is operating correctly.

3 Lighting control of camera head:

- Turn the light intensity up and down.

Introducing the Inspection Equipment into the Site

Push-camera System

The illustration below shows a typical example for the purpose of lowering the Push-camera into the ATEX Zone1 Hazardous Environment. Take care when lowering the camera to avoid contact with the inspection chamber walls.

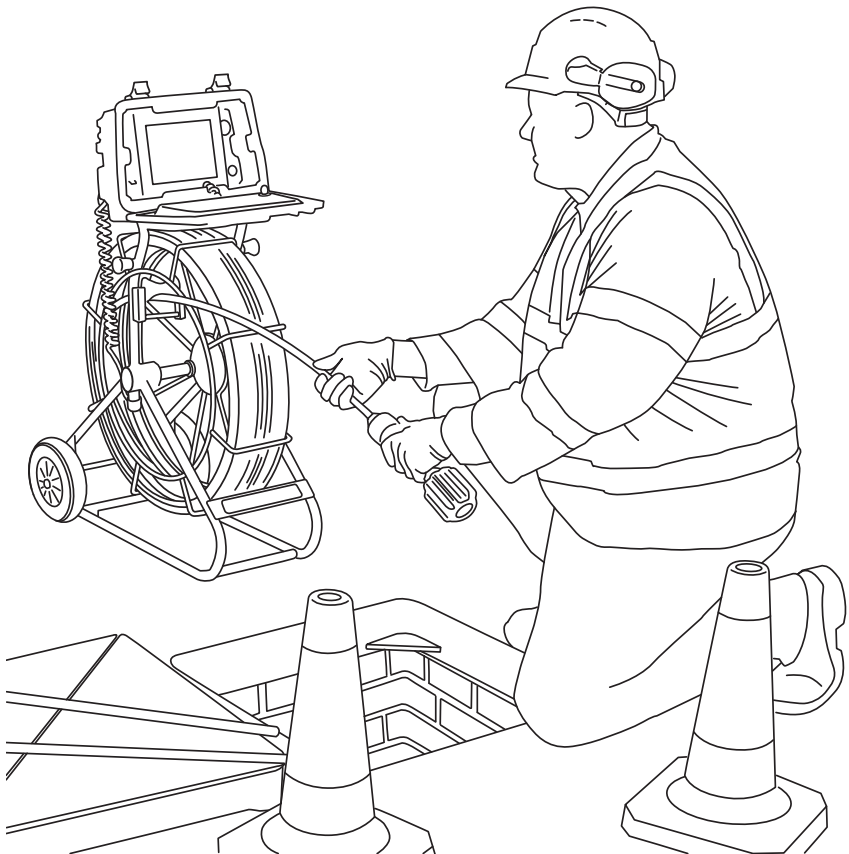

During the Inspection

During ATEX inspections you should keep the inspection equipment power ON at all times, unless there is reason for you to manually remove the power (or because ATEX-1 monitoring has removed the power itself). This is in order to ensure that the pressure and compliance monitoring of the inspection equipment is constantly active throughout the inspection.

Pressure and Compliance Monitoring

Pressure Warnings

All the time that the inspection equipment is powered ON, the pressures of the inspection equipment are being monitored. If a pressure begins to get low, the CCU shows a series of warnings.

Advisory Warning

The **first** warning is advisory – the inspection equipment pressure is getting low, and you should re-pressurise at the earliest opportunity. The warning tells you which inspection equipment is getting low on pressure.

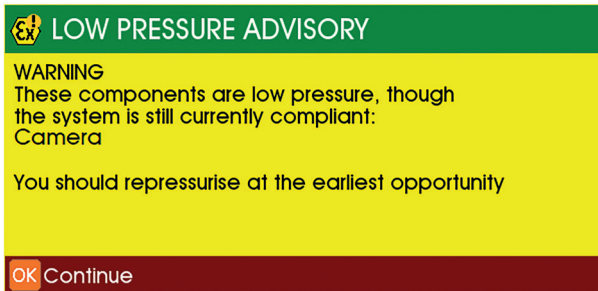

You must press OK to acknowledge this warning. The inspection equipment can still be used as the pressure is still Compliant.

Cautionary Warning

The **second** warning is cautionary – the inspection equipment pressure is getting near to the Uncompliant low pressure, and you should consider whether the remaining pressure is adequate for you to continue the inspection, or whether you should abandon the inspection and re-pressurise before continuing.

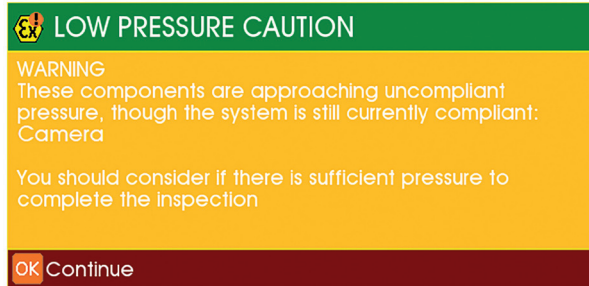

You must press OK to acknowledge this warning. The inspection equipment can still be used as the pressure is still Compliant.

ATEX-1 Pressure Uncompliant

When the system is in ATEX-1 Zone mode and the pressure in any inspection equipment falls below a 'Compliant' limit, the CCU will show an alert and the power to the inspection equipment will be removed:

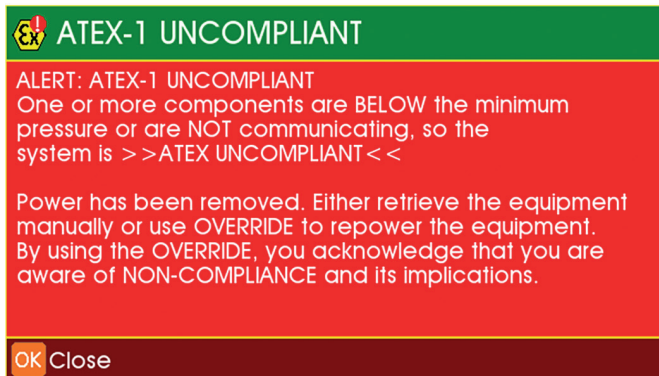

Press OK to acknowledge the alert, and then choose whether to continue using the Uncompliant inspection equipment by switching to OVERRIDE and powering ON again, or whether to abandon the survey and remove the

inspection equipment manually without power.



The equipment is liable to damage if being used with Uncompliant pressure.



The system is no longer ATEX-1 Compliant.



YOU or a qualified person must decide if to continue using Uncompliant equipment in a Hazardous Environment by using OVERRIDE. As the equipment no longer compiles with the ATEX requirements, you should NOT re-power the inspection equipment and should retrieve the inspection equipment manually. The system will make an internal log of your choice.

Manually Monitoring the Inspection Equipment

Throughout the inspection you should yourself monitor the visible condition and operation of the inspection equipment. If at any time during the inspection you have reason to think that the equipment may be contaminated, malfunctioning or damaged, you should abandon the inspection and manually remove the power to the inspection equipment yourself:

- Press the PowerON key



At the End of the Inspection

Removing the Inspection Equipment from the Site

At the end of the inspection, carefully reverse and remove the inspection equipment from the site, taking care not to cause damage to the equipment or objects around it. Remember that the Hazardous Environment may exist outside of the immediate inspection site.

Move the inspection equipment outside of the Hazardous Environment.



When you have finished the inspection and are reversing or removing the inspection equipment you should keep the inspection equipment power ON until you have removed the equipment from the Hazardous Environment. This is because if you power OFF the equipment and then find a need to re-power it while it is still in the Hazardous Environment there will be a need to make a judgement for whether re-powering is safe. This does not apply if the power has already been removed automatically by the system, for example in the case of ATEX-1 uncompliant. In these cases you should leave the inspection equipment power OFF.

Powering the Inspection Equipment OFF

When the inspection equipment is outside of the Hazardous Zone, you can power the inspection equipment OFF:

- Press the PowerON key 

You can now disconnect the equipment components.

Checking the Equipment

After each inspection you should check the equipment components for signs of wear, contamination, damage or anomalies, paying particular attention to the inspection cable for any rips, tears or cracks, and have these attended to by your Minicam approved Service Centre as soon as possible, so that the equipment is immediately usable again the next time it is needed.

If you Noticed any Problems

If you noticed any problems or anomalies while using the equipment you should make this known to your co-workers and colleagues, and report these to your Minicam approved Service Centre for attention.

Storage and Transportation

Store the inspection equipment securely during transportation to minimise the possibility of damage during transit.

Appendices

Maximum Ratings

Parameter	Minimum	Maximum	Units
Operating ambient temperature	-10	+40	Degrees C
Operating atmospheric pressure*	970	1060	Millibars
Control System operating environment	-	IP45	IP rating
Inspection Equipment operating environment	-	IP67	IP rating

**Though the system may operate outside of these pressures, ATEX-1 compliance cannot be guaranteed.*

Troubleshooting

If these troubleshooting steps do not solve the problem, contact your Minicam Service Centre.

Problem	Cause	Remedy
Inspection Equipment will not switch on	Bad connection.	Visually check all connections and cables for damage and tightness.
-OR- Inspection Equipment switches off unexpectedly	Low inspection equipment pressure.	Check "Pressure Bar" indication and re-pressurise if necessary.
	Power supply.	Check system power supply is connected and operating.
Inspection Equipment will not pressurise	Leak.	Visually check for signs of leaks or damage.
	Purge valve not tight.	Check tightness of purge valves.

WEEE Statement

Under the European Union (“EU”) Directive on Waste Electrical and Electronic Equipment, Directive 2002/96/EC, products of “electrical and electronic equipment” cannot be discarded as municipal waste anymore and manufacturers of covered electronic equipment are obligated to take back such products at the end of their useful life. Minicam will comply with the product take back requirements at the end of life of Minicam products that are sold into the EU.

For disposal contact Minicam or the Minicam partner in your country.



Information on Disposal for Business Users

Your SOLOPro+ CCU is marked with the symbol shown above. It means that used electrical and electronic products should not be disposed of in with general household waste. Contact your Local Council who will advise on the correct recycling procedure to follow.

In the European Union

Please contact Minicam or you nearest Minicam Service Centre who will inform you about the take-back of the product. You may be charged for the cost arising from take-back and recycling. Small products (and small amounts) might be taken back by your local collection facilities.

For Spain

Please contact the established collection system of your local authority for take-back of your used product.

Countries outside the EU

If you wish to dispose of your SOLOPro+ CCU, please contact your local authorities and ask for the correct method of disposal.

Batteries

As a producer of industrial batteries under the Waste Batteries and Accumulators Regulations 2009, we Minicam produce Lithium Ion batteries. We are obliged to take back free of charge, waste industrial batteries supplied to an end user for treatment and recycling. We are required to do this in any calendar year we place new industrial batteries on the market. If any of our customers or in certain cases other end users, require us to take back industrial batteries, they should contact us at:

Minicam Limited
Raven Locks
Ravenscraig Road
Bolton
M38 9PU
United Kingdom

Tel: +44 (0)1942 270524
Email: info@minicam.co.uk
www.minicamgroup.com

We will agree the necessary arrangements for the return, proper treatment and recycling of the waste industrial batteries.

Useful Information

UK Customers

For service and repair contact Minicam
Tel: 01942 270524
Email: service@minicam.co.uk

International Customers

For service and repair contact your local Minicam Approved Dealer

To view "How To" Videos visit www.minicam.co.uk



Minicam Ltd
Unit 4, Yew Tree Way,
Stonecross Park,
Golborne,
Warrington,
WA3 3JD

Tel: +44 (0)1942 270524
Email: info@minicam.co.uk
www.minicamgroup.com

