

CABLE REELS

Motorised Cable Reel

Built to the same exacting standards as our manual cable reels, these labour saving motorised reels are sturdy, rugged and built to reliably perform efficient pipeline inspections. Minicam motorised cable reels are designed for easy one-person operation in remote locations. The reels are fitted with high tensile strength Kevlar reinforced inspection cable with a weight of 5.5kg per 100m and a breaking strength of 500kg. The ultra-smooth operation is provided by the powerful three phase motor and cable layering mechanism for uninterrupted, tangle free pay-out and re-winding. A rigid, clear safety screen prevents contact with the cable whilst coiling. In the event of an emergency, the reel also features an emergency stop button. The specialised crawler connector provides a waterproof seal and there's a removable drip tray for easy cleaning and maintenance. The reel is operated using the dedicated keys and intuitive on-screen display on the Proteus Control Unit.

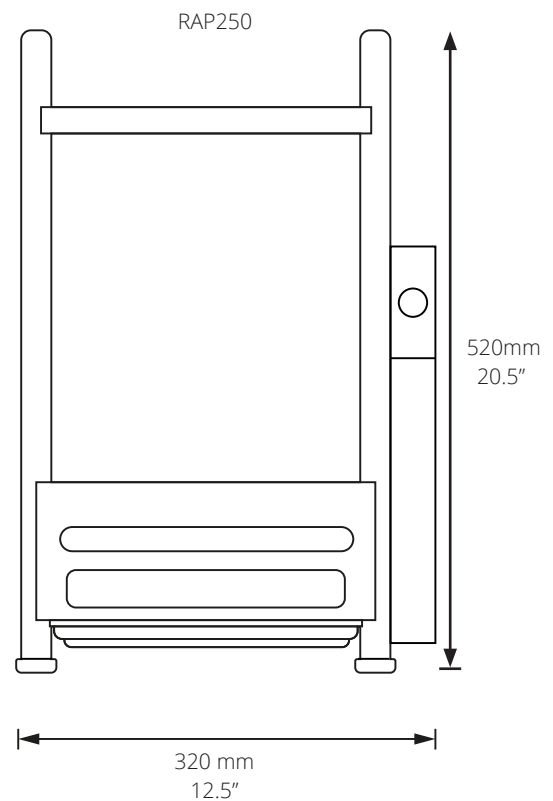
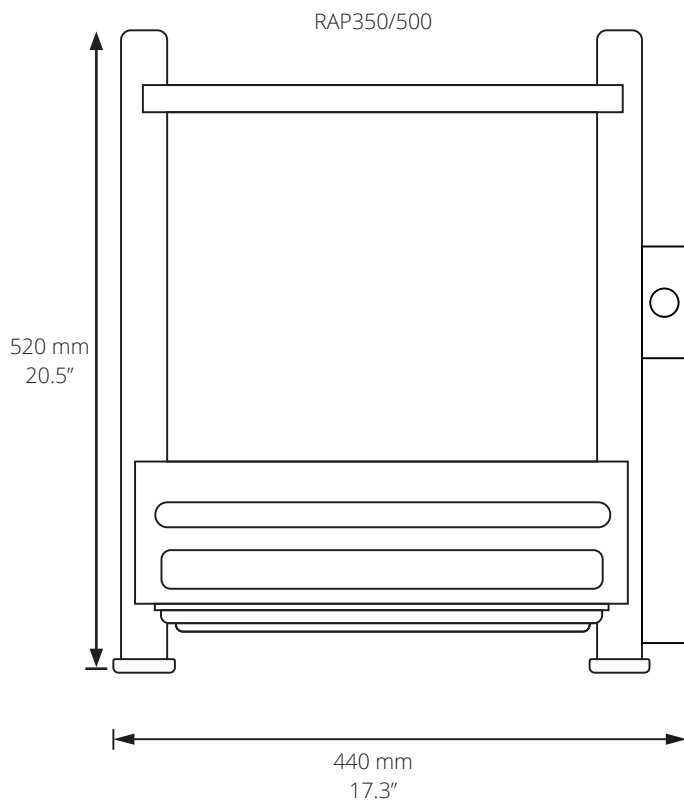

MINICAM | RAP250/350/500

CABLE REELS

SPECIFICATION

Technical Data

Product Code	RAP250	RAP350	RAP500
Cable Length	250 m 820 ft	350 m 1150 ft	500 m 1640 ft
Dimensions (L x W x H)	530 x 320 x 520 mm 20.8" x 12.5" x 20.5"	530 x 440 x 520 mm 20.8" x 17.3" x 20.5"	530 x 440 x 520 mm 20.8" x 17.3" x 20.5"
Weight	33 kg / 72 lbs	42 kg / 92 lbs	50.25 kg / 111 lbs
Power Supply	24V	24V	24V
Environmental Protection	IP45	IP45	IP45
Operational Remote Controller	RJP/RCP4	RJP/RCP4	RJP/RCP4