

Proteus Lite System

Minicam's Proteus™ Lite brings together, the tried and trusted performance and reliability of the Proteus family, in a value for money, entry level system. Proteus Lite is the ideal starter kit for a one-man operation, integration into a small inspection van, or a low-cost option for larger companies to use for off-road, remote locations. Proteus Lite provides all the resources required to undertake efficient, easy to perform inspections, and with ProPIPE+™ and WinCan® Embedded software as standard, you can deliver accurate, detailed reports, instantly on-site. The system comprises a CCU208 Control Unit, RMPL250 Reel, CPL150S Crawler and CAM026 Camera.

Compact, space-saving design, robust construction with a powder coated finish, and equipped with easy-to-use features including a manually operated cable layering arm and meterage roller, which is easily removed for cleaning. The friction brake can be fully locked, unlocked or applied as a friction brake to avoid unwanted pay-off of the cable, and a sturdy winding handle folds away neatly to save space. The cable reel comes complete with 250 metres of 6.8mm Kevlar reinforced cable with a weight of 5.5kg per 100m and a breaking strength of 500kg, and sports our signature "cow-horn" CCU locators, enabling a secure quick fit of the Proteus Lite control unit ready for work. For added flexibility an optional Tilt Table allows adjustment of the control unit position, to give the user optimal screen viewing and keyboard positions.



Compatibility

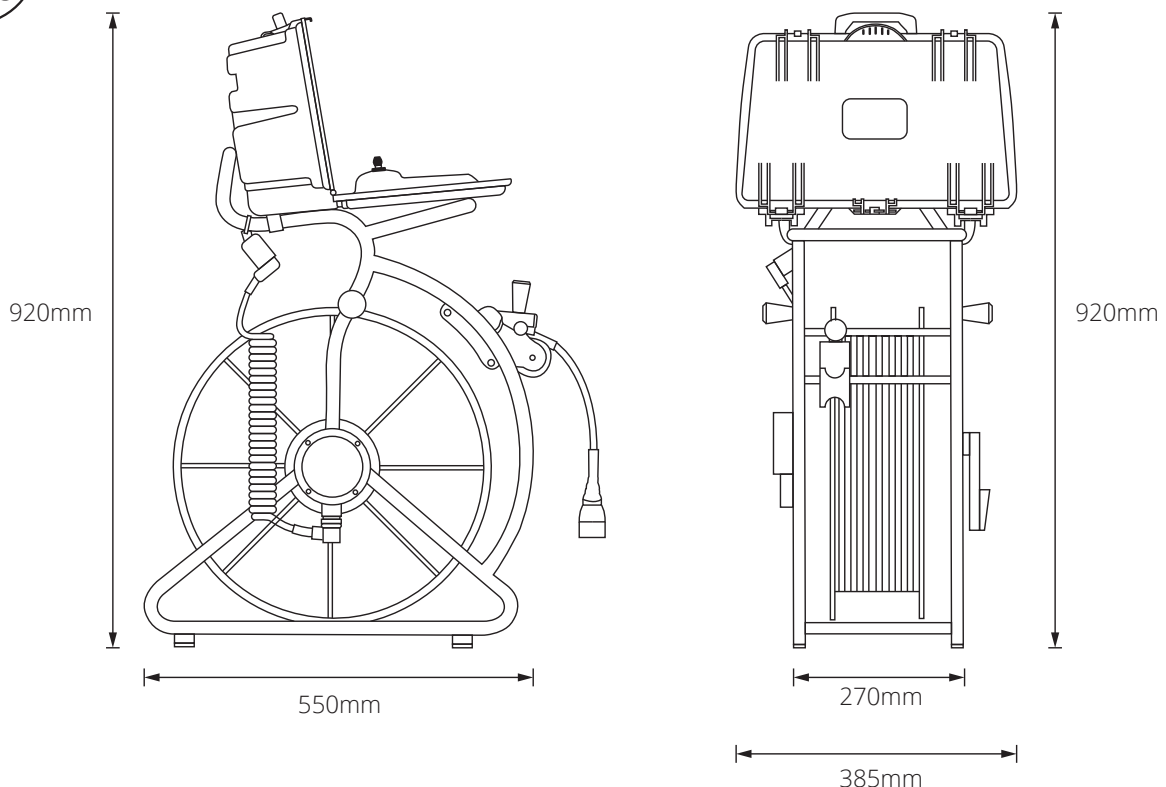

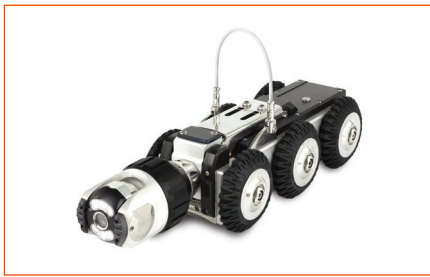

CPL150S Crawler

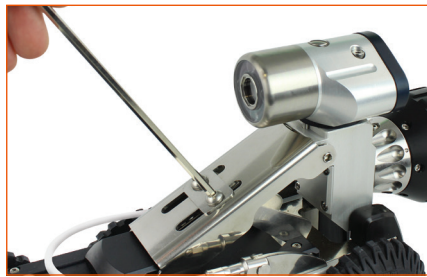

Quick Release Elevator



CAM026 360° Rotate & +/- 135° Pan

Technical Data

CCU208 Controller

Video Format	PAL
Battery	Lithium-Ion (CCU stand alone) 6 hours
Battery	Lithium-Ion (CCU and Comp Coiler) 3 hours
Charging	Mains power (100-240 Vac) or vehicle power (12 or 24 VDC) using supplied adaptors
Display	10.4" XGA (1024 x 768 pixels) Sunlight viewable
Keyboard	Full QWERTY style membrane keyboard with arrow keys for navigation and separate joysticks for camera and crawler control
Video Recording	MPEG4 (WinCan compatible)
Image Capture	JPEG (live or from recorded video)
Text Overlay	16 page (selectable text and colours)
Internal Memory	32GB (expandable to 128GB)
External Media	SDHC and USB 2.0 Memory Stick
Language Support	Multiple
Connections	Power and Cable Reel
Environmental Rating	IP54
Weight	5.5kg
Dimensions W x H x D	430 x 280 x 150mm

RMPL250 Reel

Construction	Welded Steel
Finish	Powder Coated
Distance Counter Units	Feet, Metres
Controls	Friction Brake
Weight	29.3kg
Dimensions L x W x D	550 x 385 x 700

CAM026 Pan and Rotate

Sensor	1/4" colour CCD with DSP
Effective pixels	512 x 582
Camera Sensor	470 HTVL
Sensitivity	<1.0 Lux
Aperture / Field of view	F2.5 / 75°
Image Orientation	Auto-levelling
Size	74mm (2.9in) dia
Illumination System	6 LED
Illumination Intensity	Adjustable (to 12.5K Lux at 150mm)
Construction	Aluminium / Stainless Steel
Pipe Compatibility	150mm (6") and larger
Pipe Adaptor Kit	6" / 8" Skids

CPL150S Crawler

Pipe Diameter	150mm and larger
Pressure Depth Rating	1 bar (14.50psi)
Built-in- Elevator	Manual
Quick Change Wheel Lock	
Optional Large Wheels	4 size options
Multi-Frequency Sonde Transmitter	
Inclination Sensor	
Heavy Duty Connector	
Weight	9.25 kg
Dimensions L x H x W	320 x 85 x 100mm

112021 © 2022 Minicam

