

PTP01
Portable Storage Trolley

Original
Instruction Manual

Version B

PROTEUS

PTP01 – Portable Trolley

Portable Storage Trolley PTP01 is designed to allow for the mobile operation of the PROTEUS™ Inspection System in difficult to reach areas, such as inside buildings, or other locations a distance away from your vehicle. The compact space-saving design accommodates the Digital Control Unit (not shown below), Battery Pack (BPP24), Accessory Case and 100m Motorised Cable Reel (RMP100) or 200m Motorised Cable Reel (RMP200) or 200m Manual Cable Reel (RAP200), making the whole PROTEUS™ inspection system highly portable.

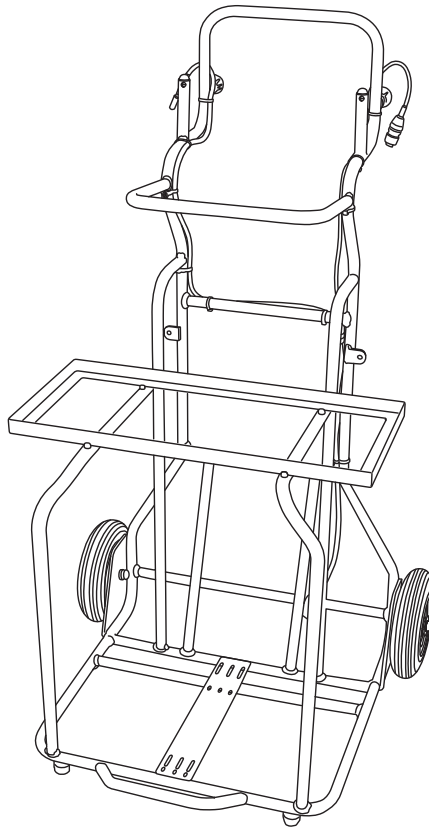

Connections and Descriptions

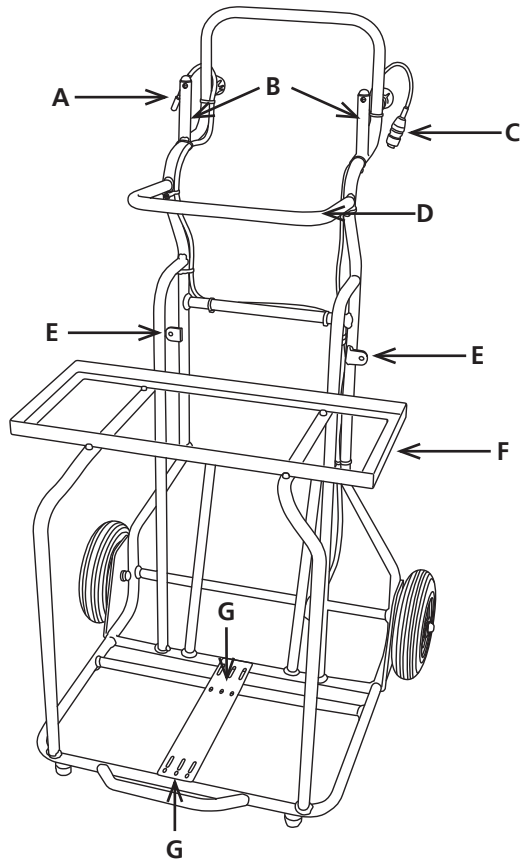

- A** Cable reel link cable for (Minicam Part No. LCP1.5).
- B** CCU location pins
- C** Battery pack link cable (Minicam Part No. ASS-002-974).
- D** Keyboard support.
- E** Battery pack fixing brackets.
- F** Accessory box tray.
- G** Cable reel (RMP100/RMP200/RAP200) fixing locations.

Equipping PTP01 Portable Storage Trolley

The PTP01 Portable Storage Trolley is delivered fully equipped* from the factory. Should you need to remove, then replace any of the equipment, please follow the instructions below.

Control Unit

1 Position the CCU by aligning the location apertures (x) on the back of the CCU over and down onto the CCU location pins (B).

Battery Pack

- 1 Attach the fixing plates (y) to the back of the battery pack using the nuts and bolts provided.
- 2 Align the fixing plates to the fixing brackets (E).
- 3 Secure the battery pack in place using the nuts and bolts provided.

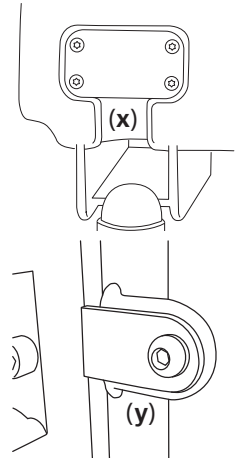

Accessory Box

The accessory case supplied with your PROTEUS™ inspection system should be positioned into the accessory box tray (F).

Cable Reel RMP100-RMP200

- 1 Position the cable reel onto the bottom section of the trolley.
- 2 Align the hole at the base of the brake side of the cable reel with the hole in the cable reel fixing bracket (G). Align the hole at the base of the opposite side of the cable reel with the cable reel fixing bracket (Gi) for RMP100 or (Gii) for RMP200.
- 3 Secure the cable reel to the brackets using the nuts and bolts provided.

• See page 6 Portable Storage Trolley Equipped

Information and Care

Maintenance

Ensure that trolley frame and wheels are free from debris and dirt.

**When purchased with a system*

PTP01 Portable Storage Trolley Equipped

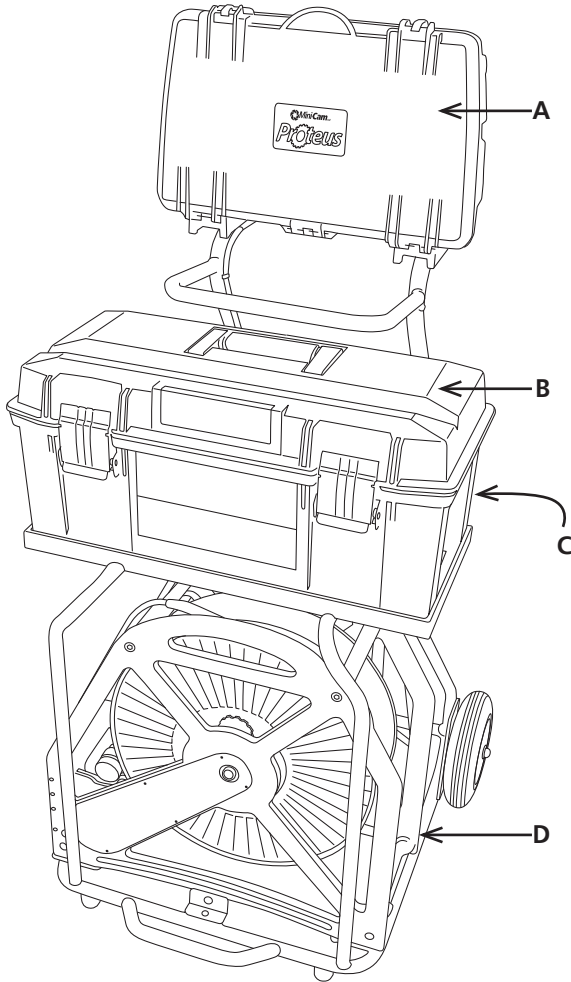

- A Digital Control Unit
- B Accessory Case
- C Battery Pack (*behind Accessory Case*)
- D Cable Reel

Technical Details - PTP01

Product ID:	PTP01
Dimensions:	650 x 1150 x 720mm (Wx H x D)
Weight:	9.75Kg (21.5lb) Unladen

NOTES



Minicam Ltd
Unit 4, Yew Tree Way,
Stonecross Park,
Golborne,
Warrington,
WA3 3JD
United Kingdom

Tel: +44 (0)1942 270524
Email: info@minicam.co.uk
www.minicamgroup.com

