

PROTEUS

Floatation Raft

FRP01

Original Instruction Manual

Version B



FRP01 – FLOATATION RAFT

Eliminate the need for man-entry. The floatation raft features three extremely powerful angled auxiliary LED ultra-bright light modules to provide enough light to illuminate pipes in excess of 2000mm. Small enough to be lowered down most common sizes of manhole cover, the compact design allows inspection capabilities in pipes from 600mm.

Designed and manufactured in-house to exacting standards, the tough polyethylene construction of the raft body is impact resistant and designed to withstand challenging inspections. An in-built lowering loop makes for quick and easy deployment and retrieval, and the factory tested floatation plate ensures the device is perfectly balanced to eliminate rolling.

Simply plug and play* with an existing Proteus System

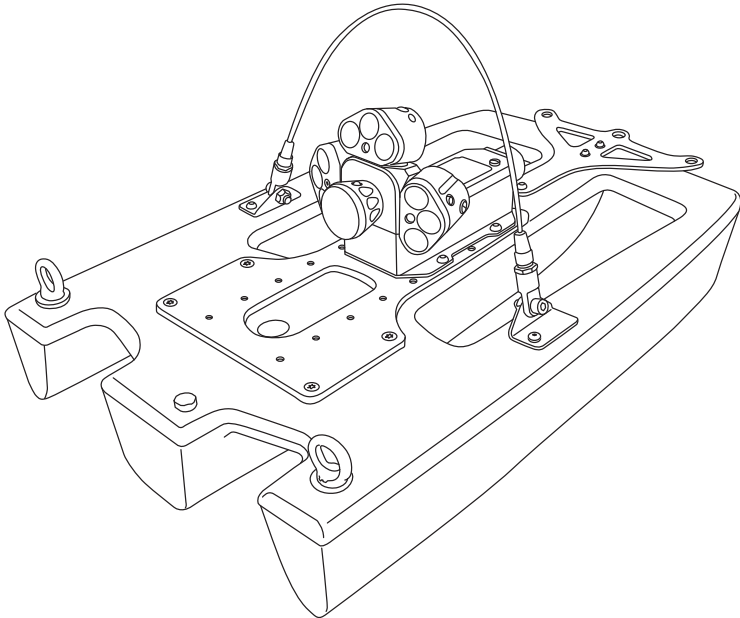

**Additional software may be required*

Parts and Descriptions

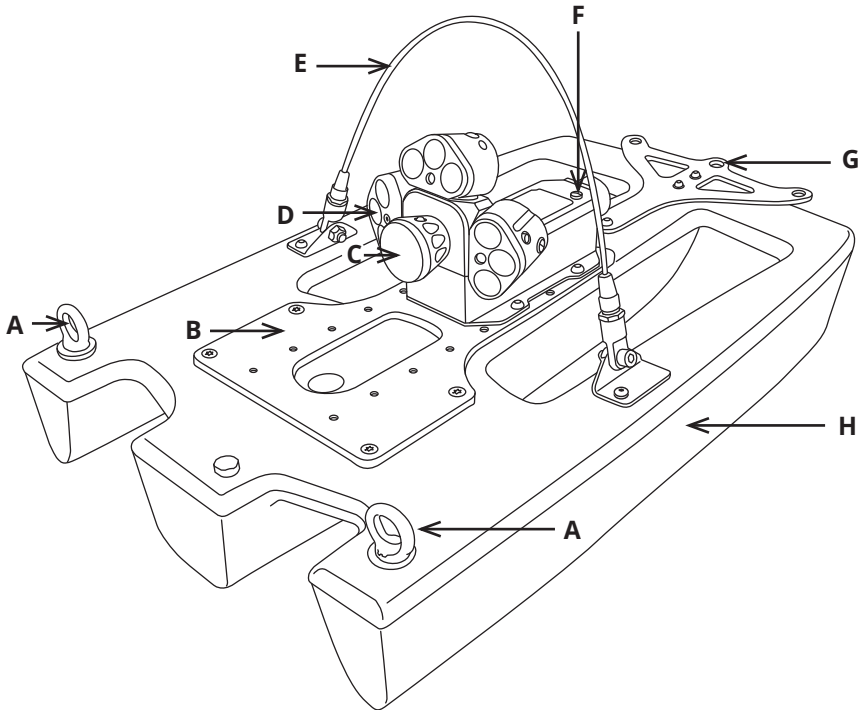

- A** Guide Eyelet
- B** Balance Plate
- C** Camera Connector Protection Cap
- D** LED Auxiliary Light Cluster
- E** Lowering Loop
- F** Pressure Valve Protection Cap
- G** Strain Relief
- H** Raft

Connection of Cabling between Cable Reel and Raft

Connect the cable reel cable to the back of the floatation raft as illustrated:

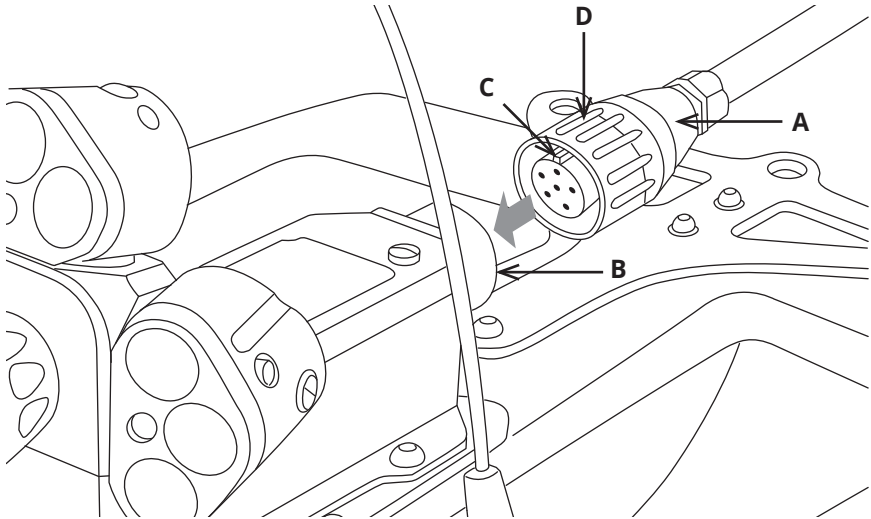

- 1 Plug the female plug of the cable reel (**A**) into the connector at the rear of the raft (**B**). Notice the orientation of the plug (**C**).
- 2 Turn the retaining ring (**D**) clockwise, as viewed from the cable, to lock the plug into the connector at the rear of the raft (**B**). The retaining ring is not able to unscrew itself during use, providing it is cleaned and maintained.



IMPORTANT!

KEEP ALL ELECTRICAL CONNECTIONS AND CONTACTS FREE OF DIRT, GREASE AND MOISTURE AT ALL TIMES.

Disconnecting Cabling between Cable Reel and Raft

Disconnect the cable reel cable from the back of the floatation raft as illustrated:

- 1 To unscrew the retaining ring you must pull the ring away from the body of the floatation raft before rotating anti-clockwise.

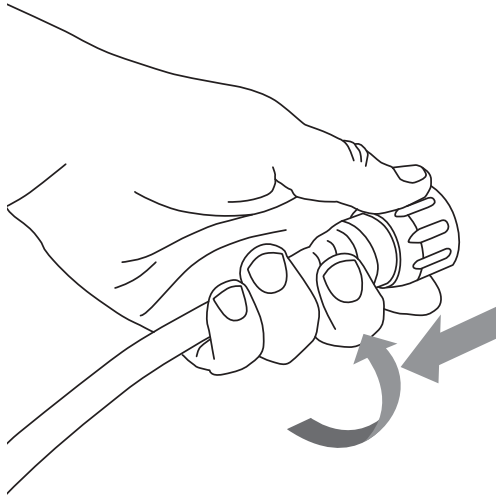

NOTE!

Always fit the protective caps when the raft or camera are not in use to protect from ingress of dirt and moisture.

Connection of Camera to Floatation Raft

Connect the camera to the floatation raft as illustrated:

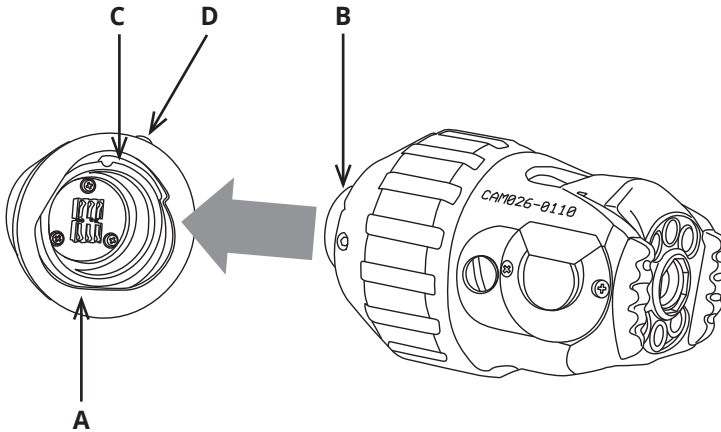

- 1 Ensure the connections are free of debris, dirt and moisture.
- 2 Ensure the locking ring (**A**) is rotated fully clockwise, as viewed in the diagram.
- 3 Notice the orientation of the camera (**B**). Orientation pin locates here (**C**). Fit the camera.
- 4 Turn the locking ring (**A**) anti-clockwise, as viewed in the diagram, to lock the camera onto the raft.
- 5 Turn the grub screw (**D**) to lock the retaining ring in position using a 3mm Allen Key.
- 6 Removal is the opposite of fitting.



NOTE!

Grub screw has a mushroom head and cannot be fully removed. DO NOT OVERTIGHTEN!



NOTE!

Always fit the protective caps when the raft or camera are not in use to protect from ingress of dirt and moisture.

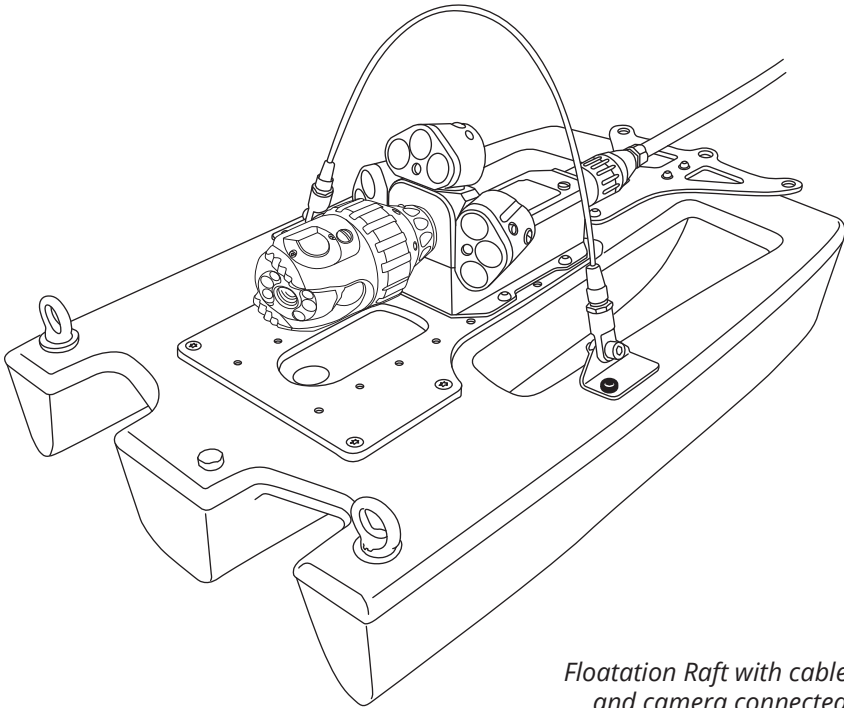

*Floatation Raft with cable
and camera connected*

Information and Care

Maintenance

Ensure all parts are free from debris and dirt.

Instructions for pressurising the FRP01 Floatation Raft

- 1 Connect the PROTEUS™ inspection system and apply power.
- 2 Unscrew the pressure valve protection cap (1)

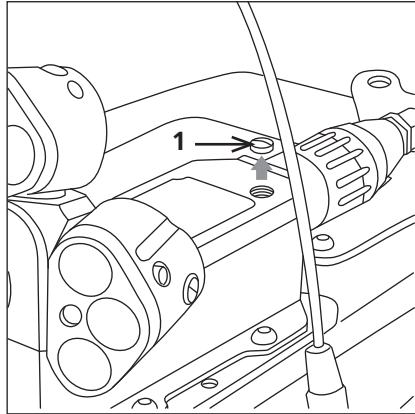

- 3 Screw on the pressure valve (2).

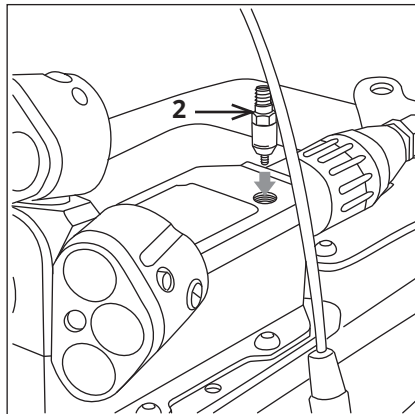

- 4 Set the pressure regulator for the CO₂ or nitrogen to 10 PSI.

5 Ensure the floatation raft pressure is within the acceptable range by checking the pressure gauge on the control unit. An example is shown below. Refer to the CCU section of this manual on specific instructions on how to access the pressure gauges.



Image shows an example of the control unit raft pressure gauge:

- 6** Remove the pressure valve (2).
- 7** Refit the pressure valve protection cap (1).

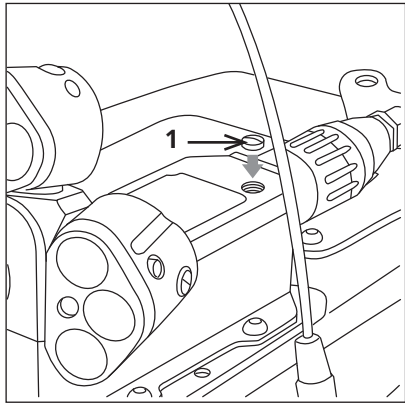
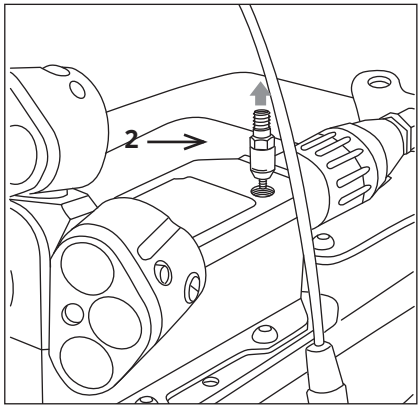

Technical Details - FRP01

Product ID:	FRP01
Dimensions:	680 x 420 x 200mm (L x W x H)
Weight (without camera):	5.8Kg (12.7lb)
IP Rating:	IP68

WEEE Statement

Under the European Union (“EU”) Directive on Waste Electrical and Electronic Equipment, Directive 2002/96/EC, products of “electrical and electronic equipment” cannot be discarded as municipal waste anymore and manufacturers of covered electronic equipment are obligated to take back such products at the end of their useful life. Minicam will comply with the product take back requirements at the end of life of Minicam products that are sold into the EU.

For disposal contact Minicam or the Minicam partner in your country.



Information on Disposal for Business Users

Your SOLOPro+ CCU is marked with the symbol shown above. It means that uselectrical and electronic products should not be disposed of in with general household waste. Contact your Local Council who will advise on the correct recycling procedure to follow.

In the European Union

Please contact Minicam or you nearest Minicam Service Centre who will inform you about the take-back of the product. You may be charged for the cost arising from take-back and recycling. Small products (and small amounts) might be taken back by your local collection facilities.

For Spain: Please contact the established collection system of your local authority for take-back of your used product.

Countries outside the EU: If you wish to dispose of your SOLOPro+ CCU, please contact your local authorities and ask for the correct method of disposal.

Batteries

As a producer of industrial batteries under the Waste Batteries and Accumulators Regulations 2009, we Minicam produce Lithium Ion batteries. We are obliged to take back free of charge, waste industrial batteries supplied to an end user for treatment and recycling. We are required to do this in any calendar year we place new industrial batteries on the market. If any of our customers or in certain cases other end users, require us to take back industrial batteries, they should contact us at:

Minicam
Unit 4, Yew Tree Way,
Golborne,
Warrington,
Cheshire,
WA3 3JD
United Kingdom

email: info@minicam.co.uk

Telephone +44 (0) 1942 270524

We will agree the necessary arrangements for the return, proper treatment and recycling of the waste industrial batteries.

Useful Information

UK Customers:

For service and repair contact Minicam

Tel: 01942 270524

Email: service@minicam.co.uk

International Customers:

For service and repair contact your local Minicam Approved Dealer

To view "How To" Videos visit:

www.minicam.co.uk

Product Serial Numbers

Enter your product serial numbers below for future reference:

PRODUCT

Floatation Raft FRP01

SERIAL NUMBER

--	--	--	--

Notes



Minicam Ltd,
Unit 33, Ravenscraig Road,
Little Hulton,
Salford,
M38 9PU
United Kingdom

Tel: +44 (0)1942 270524
Email: info@minicam.co.uk
www.minicamgroup.com

